



**Windows can account for up to 25 percent of total house heat loss. This fact sheet describes affordable and effective options to improve the energy efficiency of the windows in your house**

### Why Should I Worry About My Windows?

- **"My heating bills are out of this world. What's the problem?"**—Heat loss through and around your windows is costing you more money than you might think.
- **"I can't sit beside some of the windows in my home because of their cold surfaces and drafts."**—Cold air entering your house through cracks and crevices around windows can make for an uncomfortable living environment.
- **"Condensation and frost on my windows are creating mould and rotting the frames."**—Excessive condensation can be a sign that a window needs some work.

Windows allow natural light and fresh air to enter our houses, provide a view to the outdoors and can serve as vital emergency exits. But windows can also be responsible for unnecessary heat loss, high energy consumption and cold drafts and can be subject to condensation problems.

This fact sheet explains how you can help ensure that these problems are kept to a minimum by improving the energy efficiency and performance of your windows using products that are available at your local hardware or building supply store.

### The Benefits of Energy-Efficient Windows

Energy-efficient windows will:

- **increase your comfort.** Energy-efficient windows reduce cold drafts and make a house feel warmer during the heating season.
- **help control condensation.** The interior surfaces of energy-efficient windows stay warmer, which means you can maintain a higher level of relative humidity without worrying about condensation on the windows (keep in mind that efficiency improvements to windows will not prevent condensation if the humidity level in your house is too high).
- **save you money.** Minimizing air leakage and improving the thermal performance of your windows, by adding interior storm windows, for example, could improve their energy

efficiency by up to 50 percent and reduce your energy bills.

- **last longer.** Condensation can cause premature deterioration of windows, as well as walls and finishes, leading to costly maintenance or replacement.
- **improve indoor air quality and contribute to a healthy living environment.** By reducing condensation, energy-efficient windows help prevent mould growth.
- **reduce the penetration of dust, dirt, insects and sound into your home.**
- **reduce energy consumption and its impact on the environment.**

## Window Parts

To undertake the work described in this fact sheet, you will need to be familiar with some basic window terminology. Figures 1 and 2 indicate the main parts of a window.

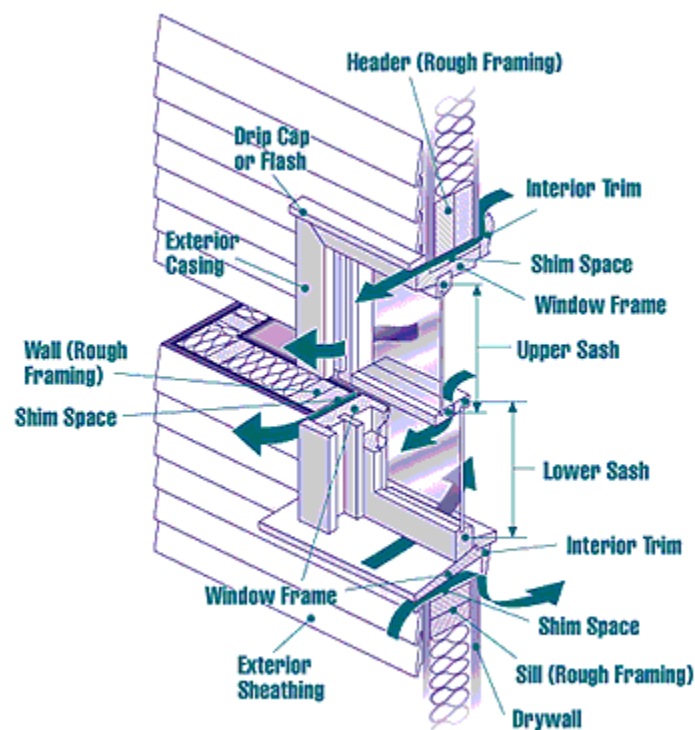

**Figure 1 Double-hung window showing parts and air leakage paths**

Windows generally consist of a frame, sash and glazing. The glazing (usually glass) fits into the sash, which in turn is held in place in the wall by the frame. The trim provides a finish around the window. In general, fixed windows are more energy-efficient than operable windows of the same size, material and orientation because they are more airtight and have more glazing (relative to frame). This extra glazing area allows more solar heat to enter the house during the heating season.

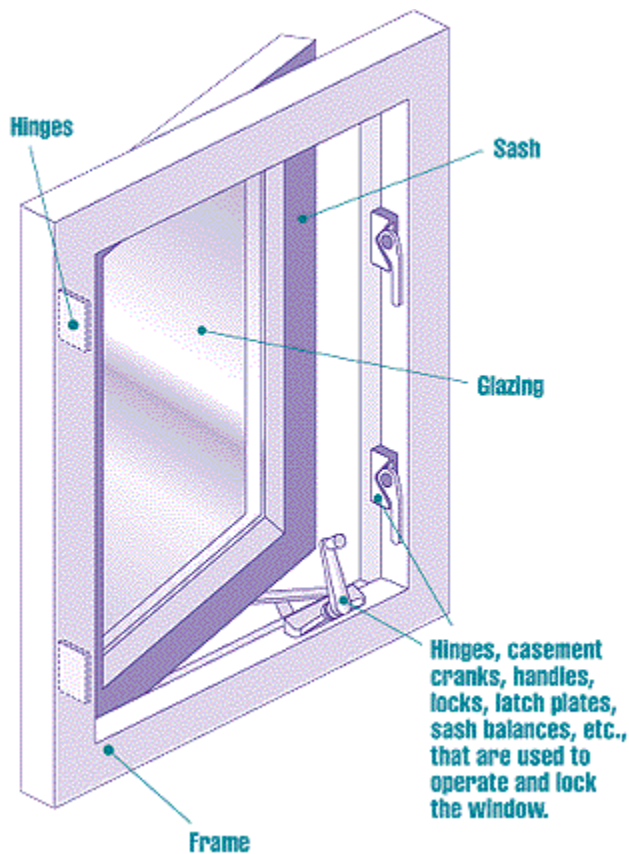

**Figure 2 Casement window showing parts and hardware**

Operable windows have sashes that move within the frame, which allow them to be opened to provide fresh air or to serve as an emergency exit. Operable windows require weatherstripping-strips of resilient material positioned at the window's moving joints to deflect rain and dust and to minimize air leakage. There are several styles of operable windows, including vertical sliders (Figure 1), casement (Figure 2), awning, hoppers, horizontal sliders and tilt-and-turn units.

### Repairing Operable Windows

Some of the most common problems with operable windows relate to ease of operation and the working of the hardware.

If the window appears to be in good shape, it may be possible to improve airtightness by the following:

- adjusting or replacing the sash locks or adding more locks to large windows
- repairing or replacing hinges on casement windows
- ensuring that caulking, weatherstripping and paint are not interfering with the operation (opening/closing) of the window
- ensuring that weatherstripping is fully functional (i.e., it should be flexible, be properly located and make full contact between the sash and frame)

Proper window maintenance includes annual cleaning of the hardware, tightening of hardware

screws and lubrication of moving parts. You should also replace any cracked glazing. If major repairs are required, consider seeking the services of a contractor.

## Indoor Air Quality and Condensation

Sealing against air leakage can reduce heat loss and energy bills, but it can also affect indoor air quality by reducing natural ventilation or by restricting the amount of air available for certain combustion appliances (which may cause them to spill dangerous by-products into the house).

As well, you should be aware that in some cases, improving the airtightness of existing windows or installing energy-efficient windows can lead to increased condensation because moist air is trapped in the house. Take steps to address the moisture problem by reducing the sources of moisture.

If you are undertaking extensive air leakage control measures or if your house is experiencing moisture problems, consult the publications offered by the Office of Energy Efficiency (OEE) of Natural Resources Canada (NRCan) or those offered by the Canada Mortgage and Housing Corporation (CMHC) for information on indoor air quality and / or condensation.

Contact information for the [OEE](#) and [CMHC](#).

### What are Your Options?

The following are four basic options for upgrading the energy efficiency of your windows:

- **repair** (see box above)
- **retrofit**, using caulking and weatherstripping
- **reglaze**, by installing exterior or interior storm windows
- **replace** the window or parts of the window

**Assess the Situation**-As a first step, carefully assess the condition of each window in your house. Check for ease of operation and note whether the window has any defects, such as loose joints or glazing, warpage, damaged or worn weatherstripping, rot or faulty hardware. You may find that some windows need only minor air-sealing work, while others may require major upgrading or even replacement.

**Do It Yourself or Hire a Contractor?**-The products and systems described in this fact sheet are widely available at hardware and building supply stores and are generally easy to use. However, some projects (particularly window replacement) will require the services of an experienced contractor. For information on hiring a contractor, request a copy of the Canada Mortgage and Housing Corporation (CMHC) booklet Before you Renovate... Renovation Guide and Catalogue. Contact information for [CMHC](#) is at the end of this fact sheet.

[View other](#) | [View to Print](#) | [Next Section](#)



## Retrofit-Start with the Basics

One of the quickest and easiest ways to reduce heat loss through windows is to seal air leaks using caulking and weatherstripping. This low-cost, do-it-yourself project can have a positive impact on your heating bills and home comfort.

Finding air leaks is simple. On a cold or windy day, take a thin piece of tissue or plastic and hold it near your window frames. If the tissue or plastic flutters, you've found an air leak. You can also detect a draft using the smoke of a lit incense stick as an indicator. The next step is to seal the with caulking or weatherstripping.

**Caulking**-Caulking is used at fixed joints, such as where the interior window trim meets the wall or where the sash and frame come together in a fixed window. Make sure the product is intended for indoor use, can be painted and is of good quality.

On some windows, air leakage can be reduced by applying a continuous bead of caulking around the window trim, at the mitred joints of the trim, and between the trim and the frame (Figure 3). If a window is particularly leaky around the trim area and the trim can be easily removed and reinstalled, consider removing the trim, adding insulation and sealing the gap before reapplying the trim. If the gap is small (1/4 in. [6 mm] or less), insulating the gap and caulking may suffice. Larger gaps may require the use of either a backer rod with caulking (Figure 4a) or insulating low-expansion foam applied from an aerosol dispenser (Figure 4b).

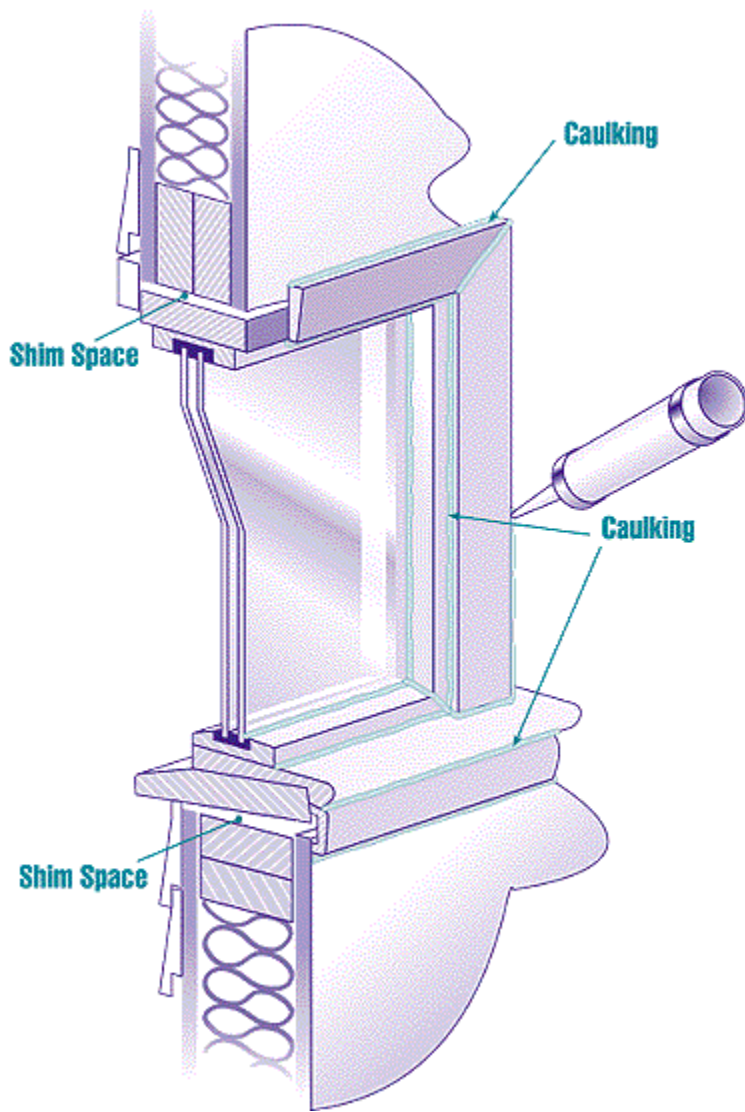
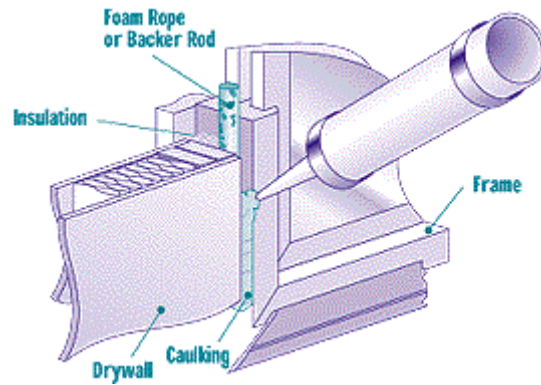
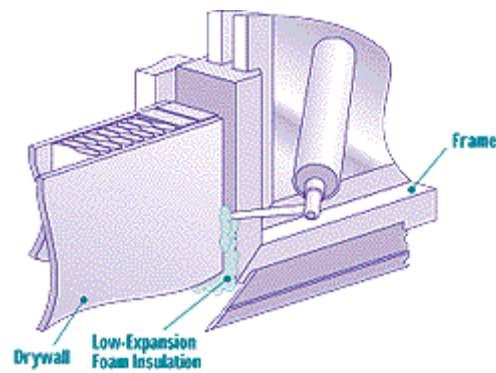

Figure 3 Where to caulk joints of a fixed window





### Figures 4a and 4b How to seal behind the window trim

If you have operable windows that you do not intend to open and that are not needed as emergency exits, consider sealing them shut for the winter using easy-to-remove tape or peel-and-strip caulking.

## Exterior Caulking

Exterior caulking is used primarily to prevent rain from entering the wall from the outside. Caulking on the outside of a window should be done only after interior sealing is complete. If the exterior is caulked first, it can trap warm, moist air in the wall, which can, in time, damage the wall.

**Warning:** Do not use exterior caulking products indoors as they may give off harmful fumes.

[Previous Section](#) | [View to Print](#) | [Next Section](#)



**Weatherstripping**-Weatherstripping is used to prevent air leakage at the parts of an operable window that move (Figures 5, 6 and 7). In most cases, it is a simple task to replace worn weatherstripping or to install additional weatherstripping if required. Good quality weatherstripping costs more but will pay for itself by performing better and lasting longer. Check with knowledgeable salespeople when selecting a product.

For older wood windows, look for a good quality, self-adhesive plastic V-strip weatherstripping. This product can be installed in very small spaces, works in both sliding and hinged applications, and can often be installed without removing any part of the window. Hinged windows usually require a combination of V-strip and compression-type weatherstripping. Follow the manufacturer's instructions when installing either of these products.

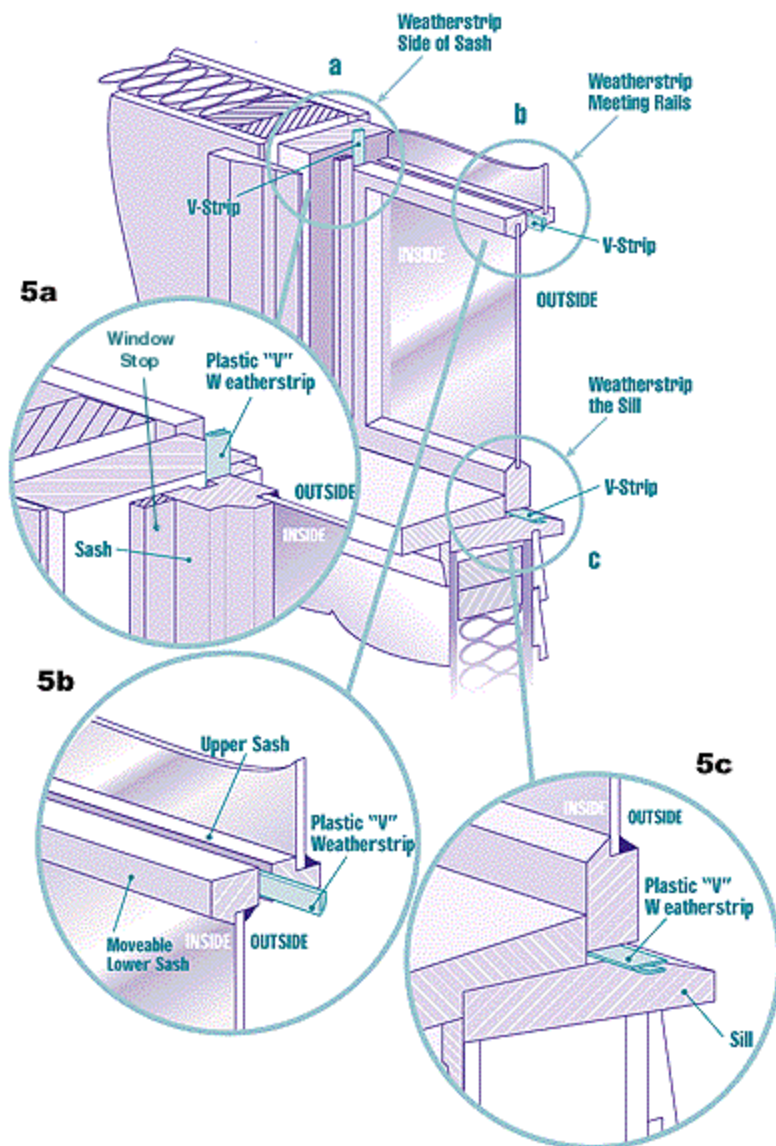

### Figures 5a, 5b and 5c Where to weatherstrip a single-hung window

Many older houses have single-hung windows with one fixed sash and one operable sash. Use the technique shown in this figure to weatherstrip a) the side of the sash, b) the meeting point of the upper and lower sashes and c) the sill.

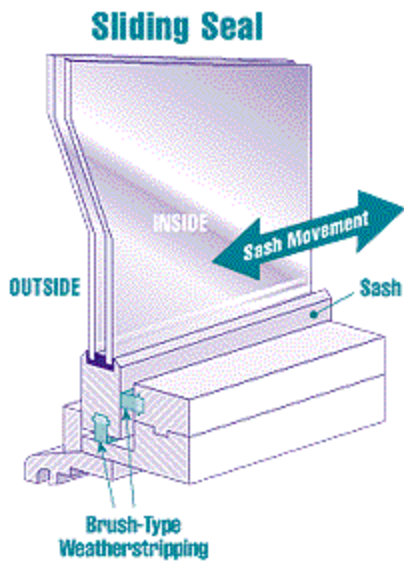

**Figure 6 Brush weatherstripping on a sliding window**

To replace brush weatherstripping on a sliding window, remove the sash and pull the old weatherstripping out of its slot. Cut the new weatherstripping to the length required, and snap or slide it into the slot. Tack or staple the ends of the brush to ensure that it stays in place before reinstalling the sash.

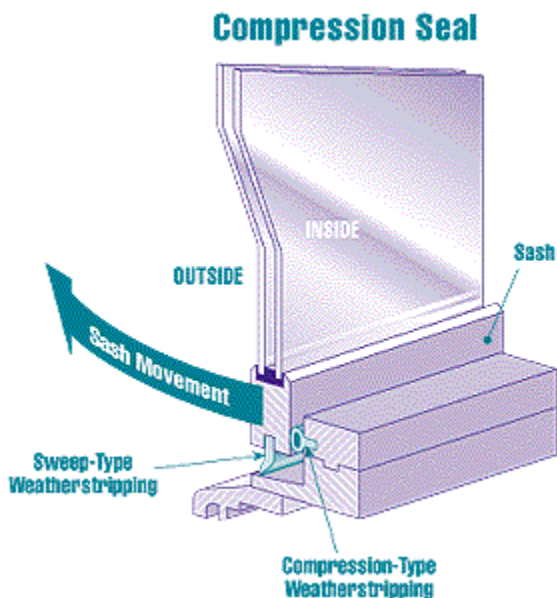

**Figure 7 Compression and sweep weatherstripping on a casement window**

[Previous Section](#) | [View to Print](#) | [Next Section](#)



## Reglazing-Storm Window Systems

It's difficult to go wrong with caulking and weatherstripping as a first step in upgrading your windows. However, while these measures can reduce air leakage and drafts, they do not improve the overall thermal resistance of the window. To accomplish this, you need additional layers of glazing.

The principal benefit of multiple glazing is that air, which is a good insulator, is trapped and sealed between the layers of glass. In Canada, windows should be at least double-glazed (two layers of glass). In many regions, the additional benefits of adding a third layer of glazing to existing windows (increased comfort due to reduced heat loss and higher interior glass temperatures, as well as reduced condensation and noise) may be worth the expense.

If your windows are in good condition, extra glazing can be added quickly and easily with the installation of storm windows-either exterior or interior. A number of options are available. Keep in mind that when installing storm window systems, safety should be your foremost concern. Always make sure you have appropriate emergency exit routes before sealing off windows.

**Exterior Storm Windows**-Exterior storm windows were once very common in Canadian houses and continue to serve a useful role in many applications. They are usually constructed of a wood or metal frame, with glass or an acrylic sheet as glazing.

Exterior storm windows can be either seasonal (installed in the fall and removed in the spring) or permanent. Seasonal storm windows should be inspected each year before installation to ensure that the glazing, putty and weatherstripping are in good condition. A drawback of seasonal units is the labour involved in installing and removing them each year, as well as the need for storage. Permanent exterior storm windows are usually equipped with a built-in screen and a sliding sash. When using exterior storm windows, the main interior window must be air-sealed more tightly than the storm window to prevent moist household air from entering the space between the windows and being trapped, where it can condense and cause deterioration of the sash and frame.

### Sashless Sliders-A Special Case

Sliding windows that are panes of glass not encased in a frame are inefficient and, at the very least, should be supplemented with interior storm windows. A better solution is to have a contractor retrofit the windows by installing the existing glazing in new sashes that incorporate weatherstripping. The sashed units are then reinstalled in the original frames.

**Interior Storm Window Systems**-Interior storm window systems have gained in popularity in

recent years. They offer the following advantages:

- They are generally attached directly to the window frame, which helps reduce air leakage around the window, and can be attached in four convenient ways, as discussed below.
- If interior storm windows are well sealed, they reduce the risk of condensation because their surface is closer to warm room air. Any condensation that does occur is on the storm window, which prolongs the life of the main window.
- They are lighter and more accessible than seasonal exterior storms and are therefore particularly useful on upper floors.

### Points to Keep in Mind

- Lightweight film systems may be damaged if you have young children or pets in the house.
- Plastic systems must be kept away from strong heat sources.
- Some people may be sensitive to plastic materials, which can emit odours (particularly when their surfaces are warmed by sunlight).
- Plastic supply stores carry a special cleaner that can be used to clean lightweight film and reduce static.

One disadvantage of interior storm windows is that blinds or other window treatments may have to be repositioned to accommodate the storm window.

Interior storm windows are typically used in the winter only and are stored for the rest of the year. However, in an air-conditioned house, interior storm windows can also help keep heat out and cool air in during the hot summer months.

To minimize condensation and air leakage, interior storm windows should be sealed tightly so that no warm air gets between the storm unit and the original window after installation.

The four most common interior storm window systems are discussed below. The first two approaches involve inexpensive, do-it-yourself products, while the last two are more costly and may require the services of a contractor.

**Heat Shrink Film with Double-Sided Tape**-This is one of the easiest do-it-yourself options available to home-owners. Kits are sold at most hardware and building supply stores and include instructions for installation.

With this system, two-sided tape is used to attach the film to the window trim, after which the film is heated with a hair dryer to shrink it tightly across the window. In most cases, the film can be used only once. Although this system provides an excellent seal and good visibility, the two-sided tape can lift paint when it is removed. As well, once this system is installed, the window cannot be accessed without removing or puncturing the film.

**Clear Plastic Film with Spline and Channel**-A rigid plastic channel is permanently attached to

the window frame using small nails, screws or double-sided tape (as shown in Figure 8, a lower crosspiece is added to the sill to create a flush fastening surface). A clear plastic film is then stretched tightly across the window and snapped into place using the spline section (see Figure 8). The plastic film is reusable for several years and is airtight. One disadvantage is that the film may not be as clear as heat shrink film. The spline and channel system should last for several years.

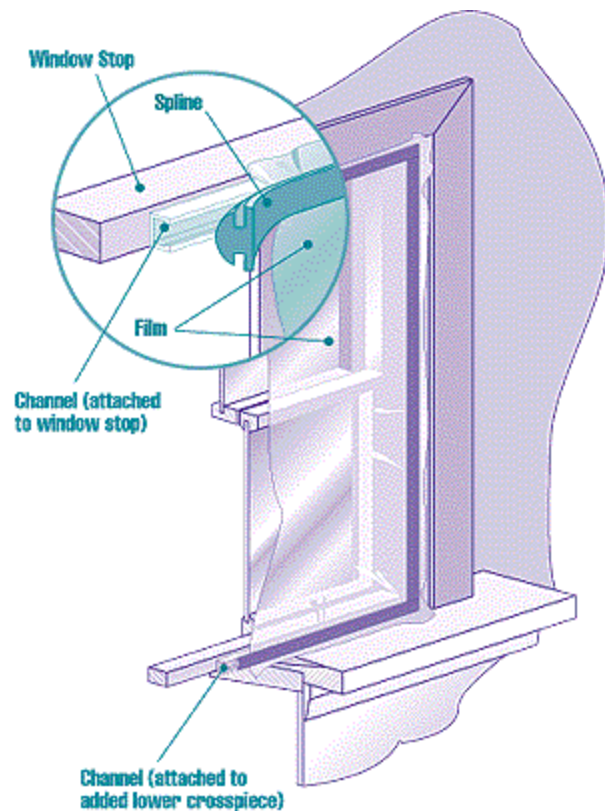

**Figure 8 Clear plastic film with spline and channel**

This system is usually sold in kits (available in a variety of colours), but the individual components can also be bought separately. Follow the manufacturer's instructions carefully when installing the spline and channel, and be sure to use the recommended thickness of film. When not installed on the window, the plastic film should be stored hanging over a rod to avoid creasing.

[Previous Section](#) | [View to Print](#) | [Next Section](#)



**Clear Rigid Acrylic Sheets with Snap-On or Magnetic Seal**—These systems are more durable than the previous two options. The snap-on system works like the spline and channel system, except that it is more substantial because it holds a heavy acrylic sheet in place (Figure 9). The rigid glazing is easier to attach and remove than film, and it is easier to clean, more durable and has a more finished appearance.

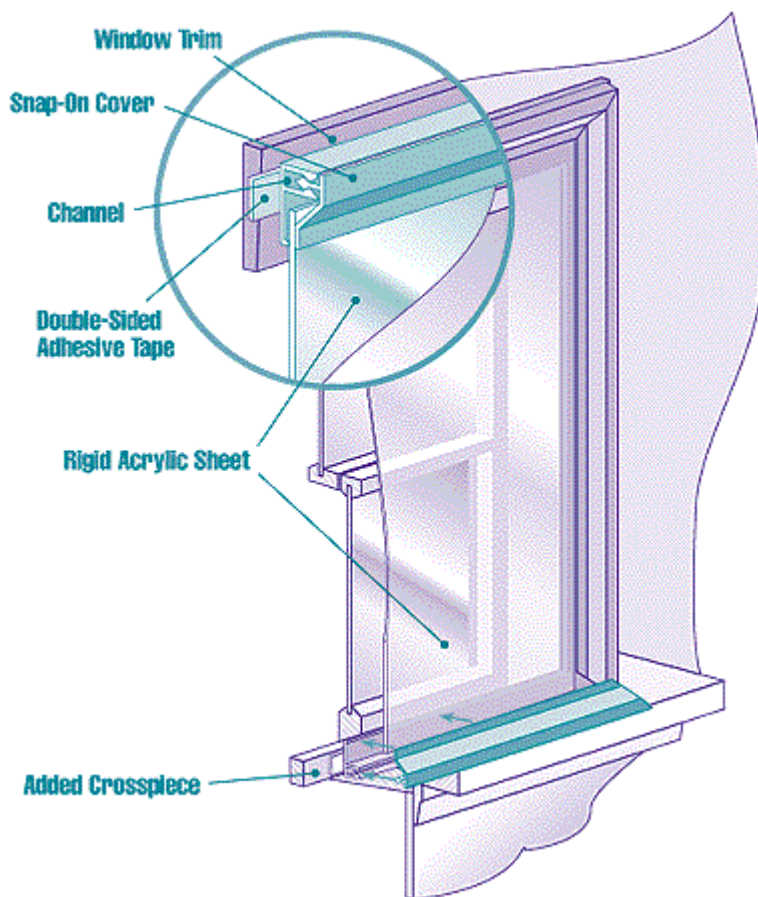

**Figure 9 Snap-on interior storm system applied to window trim**

To install a magnetic seal system, a metal strip is fastened to the window trim using double-sided tape (this strip can be painted to match the frame). A magnetic moulding is then secured to the acrylic sheet, and the sheet is pressed into place on the metal strip.

When the acrylic sheets are not in use, they must be stored in a flat or vertical position (not slanted) and in a cool place that is protected from exposure to sunlight and excessive heat.

Many plastic supply stores sell these systems and can cut the sheets to the size required. As well, some firms specialize in manufacturing and installing these systems (check your local Yellow Pages™).

The magnetic seal (Figure 10) is a popular option for heritage homes and highrise condominiums, since it is possible to make the attachment system virtually indistinguishable from the main window. However, thermal contraction and expansion and the weight of the acrylic sheet can cause the magnetic strip to release accidentally. As a precaution, a few well-placed turn buttons can be used to supplement the magnetic seal and hold the unit firmly in place.

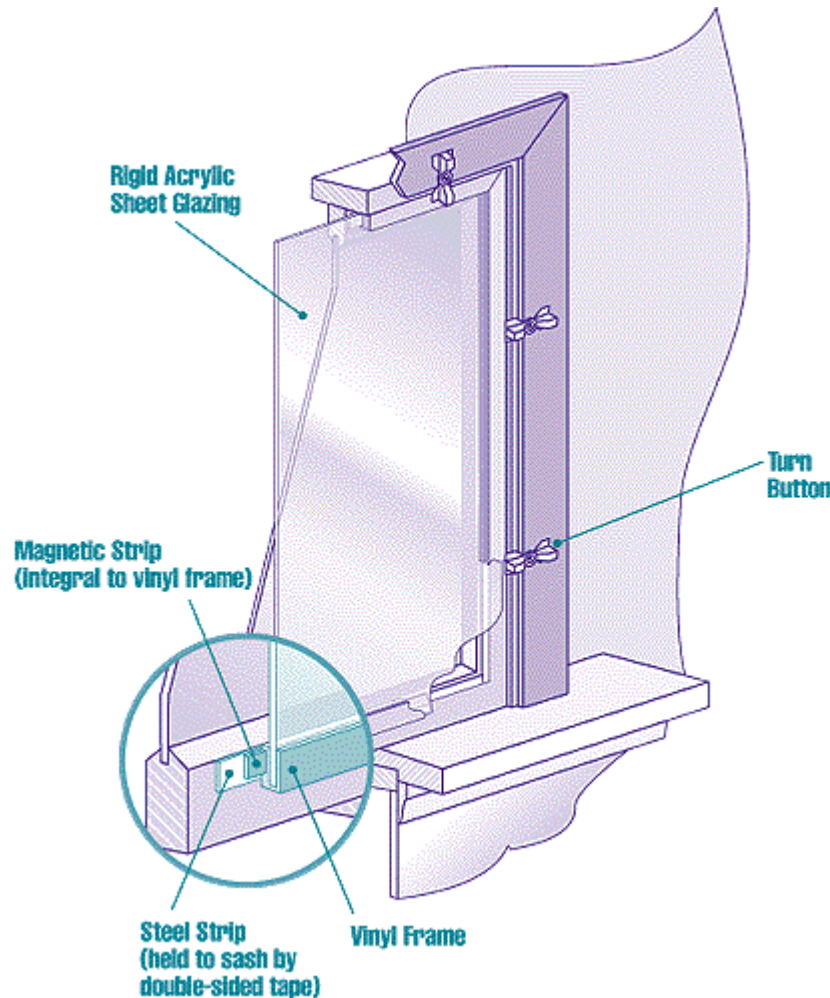

**Figure 10 Magnetic interior storm window system applied to window sash**

**Specialty Products**-Another option worth considering is a multi-layered, laminated polyester film that is black on one side and silver on the other. The film has a perforated appearance (similar to a microwave oven window) but does not allow air to pass through it. The system is attached to the window trim by means of a Velcro® fastening system. In winter, the silver surface faces in, reflecting heat back into the house. The Velcro® system allows the film to be easily reversed in summer, with the silver side reflecting solar energy back out through the main window. This product is effective at reducing unwanted air leakage in both summer and winter, but it tends to block daylight, darken the room and reduce visibility. It may be most suitable for areas that have high solar heat gain and heat loss, such as sunrooms.

### Replacing Glazing, Sashes and Windows

If your inspection has revealed serious problems with a window's glazing, sash or the entire unit, your best option may be to replace all or part of the window.

For example, if the glazing itself is only a single pane of glass or is in poor condition, consider installing a new, multi-layered insulated glazing unit. Make sure the sash is deep enough to accommodate such a unit.

If the sash has deteriorated but the frame is still in good condition, you should be able to buy a replacement sash or window. These products should be installed by professionals.

If the entire window, including the frame, is in poor condition, it may be time to replace the unit. This will be an opportunity to install a high-performance window that could include such features as double or triple glazing, inert gas fills between the glazings, low-conductivity spacers and a low-emissivity (low-E) coating that allows light to pass through a window but reflects the home's heat back into the house.

### **Where can I get more information?**

Information on window energy efficiency is available from several sources.

To order the *Consumer's Guide to Buying Energy-Efficient Windows and Doors* and a fact sheet entitled *Moisture Problems*, contact:

Energy Publications  
Office of Energy Efficiency  
c/o DLS  
Ottawa ON K1A 0S9  
Telephone: 1 800 387-2000  
Fax: (819) 994-1498  
Web site: <http://oee.nrcan.gc.ca/infosource>

---

For information on indoor air quality or order *Before You Renovate... Renovation Guide and Catalogue* (Publication No. 2384E) contact:

Canada Mortgage and Housing Corporation (CMHC)  
Canadian Housing Information Centre  
700 Montreal Road  
Ottawa, ON K1A 0P7  
Telephone: 1 800 668-2642  
Fax: (613) 748-4069  
Web Site: <http://www.cmhc-schl.gc.ca>

---

More information may also be available from your provincial energy and environment ministries and electric and gas utilities. As well, you may wish to

contact the following:

Canadian Window and Door Manufacturers Association  
27 Goulburn Avenue  
Ottawa, ON K1N 8C7  
Telephone: (613) 233-9804  
Fax: (613) 233-1929  
Web Site: <http://www.cwdma.ca>

S.A.W.D.A.C.  
Siding and Window Dealers Association of Canada  
84 Adam Street  
Cambridge, ON N3C 2K6  
Telephone: 1 800 813-9616  
Fax: (519) 658-4753  
Website: <http://www.sawdac.com>

[Previous Section](#) | [View to Print](#) | [View other](#)