 Office of Energy
Efficiency



Air leakage costs Canadian households a hefty part of their annual heating bills and makes our homes uncomfortable and unhealthy. This fact sheet shows you what to do about it.

Why Should I Worry about Air Leakage Problems?

Brrrrr... Why is this room so uncomfortable?—Cold air leaking into your house can make some rooms—particularly in the basement, on the main floor or with a windward facing wall—drafty, uncomfortable and difficult to heat, even with the thermostat turned up.

Zapp! My house is a desert!—Shocks from static electricity, creaky furniture, dry throats and skin, laundry that "clings": these are symptoms of excessive winter dryness. Cold, dry outdoor air leaking into your house is one of the villains. This air leakage reduces the relative humidity in your home. Lower humidity levels also aggravate allergies and respiratory problems. Health Canada recommends a minimum of 30 percent relative humidity.

What's happening to my attic?—Warm air leaking out of your house carries moisture in the form of water vapour. This moisture condenses in attic spaces and wall cavities, causing long-term deterioration. Problems include rotting roof sheathing, wet insulation, mould growth, buckled siding, spalling bricks and puddles in basement corners. (Natural Resources Canada [NRCan] has published a fact sheet entitled [Moisture Problems](#).)



What am I breathing?—We need fresh air in our houses. But do we really want that fresh air to be dragged in through floor drains, dusty insulation and chimney flues? Wouldn't a mechanical ventilation system, with air filtering, be healthier?

How do these bugs get in?—Crawling and flying insects make their way into your house in the summer via many of the same routes taken by air leakage in the winter. And if you have mice, just imagine how big those cracks are!

Yikes! Look at this heating bill!—Air leakage represents 25 to 40 percent of the heat lost from an older home. This costs you \$150 to \$250 per year, if you heat with natural gas, and \$200 to \$350 per year for an electrically heated home.

Won't anyone buy my house?—Most consumers will avoid buying a house that is drafty, uncomfortable, expensive to heat or has moisture problems. A leaky house usually has a lower resale value.

Does My House Have a Problem?

Start with a few basic questions:

- Are some rooms drafty or difficult to keep warm?
- Is there a lot of static electricity in mid-winter?
- Is my heating bill higher than average?
- Are there moisture problems in my attic—damp insulation, mildew or rot?

How to detect air leaks?

Cold air leaking *into* your house—at door sills or basement windows—is easy to detect, because you can feel the draft. However, warm air leaking *out of* your house—at ceiling light fixtures or upper storey windows—is almost unnoticeable.

Some contractors and consultants perform a fan depressurization test (also called a blower-door test) to calculate the airtightness of a house and use a smoke pencil to identify the location of air leaks. This test costs about \$125 to \$200 but may be worth considering if you are undertaking a major retrofit project.

You can take a simpler approach by using a household item as a "draft detector"—an incense stick, a thin piece of tissue or cellophane, or a feather glued to a toothpick.

It's best to inspect your house on a very cold or windy day. Put on your detective's cap, grab your draft detector and go through the entire house, holding the draft detector near window and door frames, electrical outlets, baseboards and other possible leakage locations. You may be surprised by what you find. (By the way, this type of inspection can also be done when you want to buy a house.)

EnerGuide for Houses

EnerGuide for Houses, a program of Natural Resources Canada (NRCan), offers unbiased, third-party home energy evaluations by qualified and licensed energy efficiency advisors in communities across Canada. Advisors use their expertise in combination with NRCan's energy-modelling software to prepare a report to help the homeowner plan for energy efficiency renovations. The report includes an EnerGuide for Houses label and rating. To contact an agent go to the EnerGuide for Houses Web site at <http://oee.nrcan.gc.ca/energguide/houses>, or call 1 800 387-2000 and ask the operator for the number of an EnerGuide for Houses representative in your area.

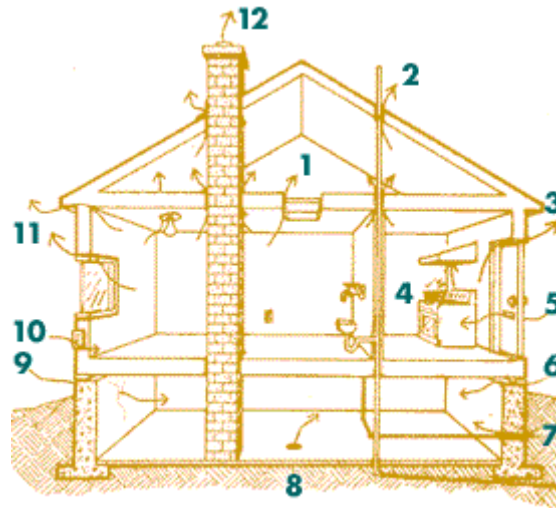

Where to look?

Here are some of the key locations to check:

- 1) attic hatch
- 2) ceiling penetrations into attic
- 3) doors
- 4) exhaust vents
- 5) mail slot
- 6) sill and header
- 7) service entries
- 8) floor drain
- 9) foundation cracks
- 10) electrical outlets
- 11) windows
- 12) chimney

How to Solve Air-Leakage Problems and Save Energy

The good news is that simple measures can cut air leakage in half in many houses. Many energy-retrofit measures also solve air-leakage problems. This section highlights some examples. For more details, obtain one of the publications listed on the last page of this fact sheet.

Weatherstrip and caulk windows and doors—A good place to start reducing air leakage is at windows and doors—your home's "Achilles heel". On traditional single-hung windows, apply V-strip and compression-type weatherstripping.

Horizontal sliders need pile-type weatherstripping. Hinged windows—casement, awning and hopper types—require combinations of V-strip and compression weatherstripping on the fixed and movable sashes. Sash locks may also need to be replaced or adjusted to ensure a snug fit.

For exterior doors, reduce air leakage around the jambs (sides and top of door) by adjusting the position of the weatherstripping or replacing it if worn. Door sills need a threshold seal, door bottom seal or a door sweep. Sliding patio doors can be sealed like sliding windows.

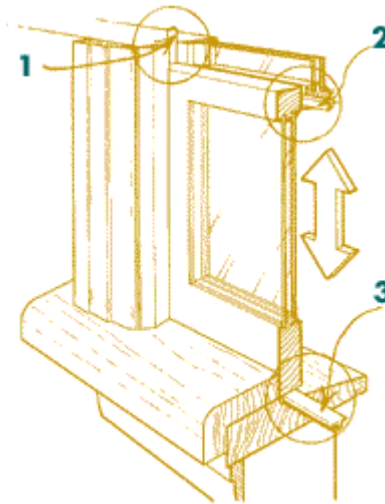

Weatherstripping single-hung windows

- 1) Weatherstrip side jambs
- 2) Weatherstrip check rails
- 3) Weatherstrip sill

Caulk around window and door trim with clear or paintable caulking. If windows or trim are being replaced, seal the gap around the window or door frame with polyurethane foam or with insulation and/or polyethylene and caulking.

Upgrade or replace windows—In addition to losing heat through air leakage, conventional single or double-glazed windows have little insulating value.

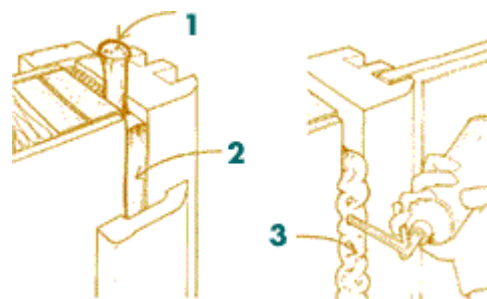

Sealing behind window trim

- 1) foam rope or backer rod
- 2) caulking
- 3) foam

If your windows are still in good condition, here's an inexpensive way of improving both airtightness and insulating value. In the fall, apply thin plastic film over the

entire window and frame, attaching it to double-sided tape on the edge of the frame or wall. Kits are available at hardware stores. It's a labour-intensive annual exercise, but it will result in a more comfortable house. Focus on upper-storey windows (where air usually leaks out) and basement windows and patio sliders (where air usually leaks in). Other systems use rigid acrylic plastic sheets or plastic film held by magnets or other fasteners to the window frame. Although these systems are more expensive, they are removable during the summer and reusable every year.

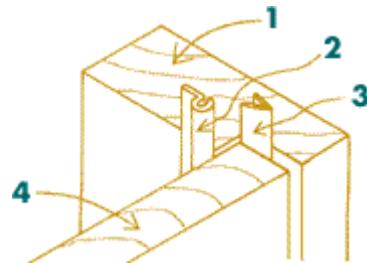

Door jamb details

- 1) jamb 2) weatherstripping at face of door
3) weatherstripping at edge of door 4) door

If you are thinking about replacing older deteriorated windows, consider upgrading to high-performance windows that have special "low-E" coatings and are filled with inert gases like argon or krypton. The additional cost is usually less than 10 percent and the energy savings are considerable. For more information on energy-efficient windows, refer to the Natural Resources Canada publication entitled, *Consumer's Guide to Buying Energy-Efficient Windows and Doors*. See the last page of this fact sheet to find out how to order a free copy.

Seal hidden openings into the attic—There are many air-leakage paths into the attic: passages for electrical wires, electrical boxes for ceiling lights, plumbing stack, chimneys, exhaust vents and the tops of partition walls. Addressing this problem can be a miserable job but well worth the effort. Pull away attic insulation, a little at a time, to expose these hidden leakage paths. Caulk or foam electrical wiring openings, exhaust fan housings and tops of walls. Use heavy polyethylene, a pipe clamp and acoustical sealant to seal around the plumbing stack.

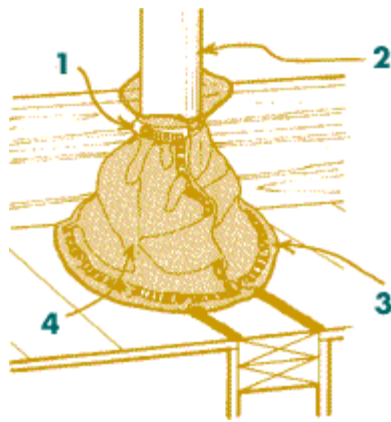

Sealing plumbing penetrations into the attic

- 1) pipe clamp
- 2) plumbing stack
- 3) acoustical sealant.
- 4) sealed polyethelene.

Some types of recessed lighting fixtures can present a fire hazard if sealed or covered with insulation and should be replaced with ceiling-mounted or wall-mounted fixtures, or fixtures that are airtight and approved to be covered with insulation.

Use sheet metal and non- combustible caulking to close the gap around chimneys.

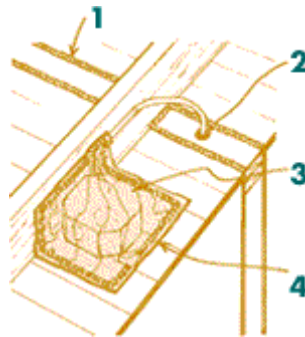

Sealing lighting and wiring penetrations into the attic

- 1) caulking along interior wall junctions
- 2) sealed wire hole
- 3) electrical box
- 4) sealed polyethylene

[View other](#) | [View to Print](#) | [Next Section](#)



 Office of Energy
Efficiency



Make the attic hatch airtight—Weatherstrip the hatch (you can also glue some rigid insulation on the back), install latches to hold the hatch snugly against the weatherstripping and caulk the trim.

Seal the top of foundations—The junction of the main floor framing and the foundation wall is seldom sealed well. Caulk the sill plate and rim joist, or place tightly fitting rigid insulation in the space between the floor joists and caulk.

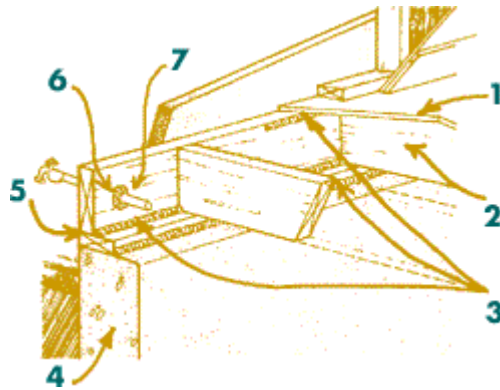

Sill and header detail

- 1) subfloor 2) floor joists
- 3) caulking 4) basement wall
- 5) sill plate 6) service penetration
- 7) header joist

Seal baseboards—Use clear or paintable caulking to seal the top and bottom of baseboards and quarter rounds, or remove baseboards and foam the gap where the floor and wall meet. The area around electric baseboard heaters is difficult to seal, but if the heaters can be removed, the hole for the wiring and the gap between the wall and flooring can be sealed. **(Turn off the power first!)**

Seal electrical outlets—Hidden air-leakage paths often start or end at electrical outlets and switches. Shut off the power, remove cover plates and install CSA-approved foam gaskets. Child-proof plugs help, too.

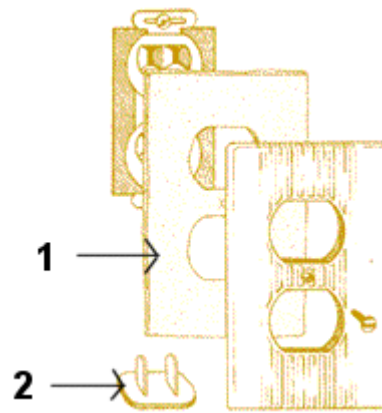
**Gasket for electrical**

- 1) gasket
- 2) child-proof plug

Close up seldom-used fireplaces—Fireplace dampers rarely fit tightly. If you don't use your fireplace regularly, consider installing a removable plywood cover, which can be insulated and weatherstripped or sealed with a gasket.

Seal ducts—If ductwork runs through unheated areas, such as attics or crawl spaces, any leaks can be costly. Seal the joints with a water-based duct mastic (sealant). Look in the Yellow Pages™ under "Furnaces—Heating" or "Furnaces—Supplies and Parts". High-temperature duct tape may work, although it tends to degrade or permit air leakage over time. Insulate ducts after sealing.

Doing It Right

Piggyback!—If you are undertaking a major renovation or putting on an addition, don't lose the opportunity to "piggyback" some air-sealing work. When interior and exterior finishing materials are removed (or before they are applied), it is much easier and more cost-effective to get at openings in the air barrier, which will become hidden later.

Ventilate right, then seal it tight!—Relying on air leakage for fresh air isn't a good strategy—you'll have too much on a windy night in January and not enough on a mild day in October. A better approach is a mechanical ventilation system. Consider installing a heat recovery ventilator (HRV), which transfers heat from the exhaust air to pre-heat the fresh air. If an HRV is not economically feasible, ensure that you have exhaust fans in the kitchen and bathrooms for removing odours and moisture, and provide a fresh air inlet (check local building regulations). Each major room in your house—particularly the bedrooms—should have a source of fresh air. In homes with electric baseboards or hot water radiators, installing ventilation ductwork can be expensive. Small-diameter ducting is now available, which makes the job easier and less expensive.

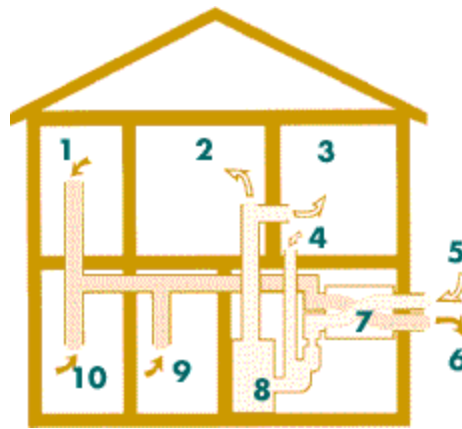

Schematic of ventilation system with an HRV

- 1) kitchen 2) living room 3) bedroom
 4) cold-air return 5) fresh air 6) exhaust air
 7) HRV 8) furnace 9) bathroom 10) laundry

Cut out the pollution—You can reduce your need for ventilation by reducing the sources of indoor air pollution in your home. The biggest offenders are tobacco smoke, new construction materials, furnishings and cleaning products. Choose environmentally friendly products or materials whenever possible.

Reduce moisture sources—While many Canadian houses are too dry in winter, others can suffer from dampness and condensation. If your house has moisture problems, reduce the sources of moisture before air sealing. Major sources include humidifiers, basement leaks, exposed earth, drying firewood indoors, showers and baths (without an exhaust fan), and drying laundry or venting dryers indoors. (For more detailed advice, view online the fact sheet entitled [Moisture Problems](#), from Natural Resources Canada.)

Select the right material

Air-sealing requires a combination of several products:

- Sheet materials: polyethylene (inside), "house wrap" (outside).
- Rigid materials: plywood, drywall, wood, concrete, metal, foam insulation board.
- Caulking and sealants: silicone, urethane foam, polysulfide, butyl rubber, acrylic latex, water-based acoustical sealant, thermoplastics, high-temperature cement, duct mastic.
- Weatherstripping: closed-cell foam, ribbed rubber, tubular stripping, spring vinyl or metal strips, spring-loaded, magnetic, door sweeps or door bottoms and thresholds.
- Gaskets: polyethylene foam for sill plates and electrical outlets, foam rope, Neoprene rubber.
- Tapes: duct tape, sheathing tape.

The publications listed on the last page summarize the advantages and limitations of each of these materials. Consider durability,

performance, appearance, paintability, and cost when buying. Always read manufacturers' instructions. Check for compatibility with surface materials. Ensure adequate ventilation when using sealants with volatile emissions.

Technical Information

If you want to know more about the science of air leakage, this section contains technical information. If not, skip to the next section.

Basic Facts About Air Leakage

The building envelope is the shell of the house that separates the heated area from the outdoors. The building envelope includes the walls, windows and doors, basement walls and floor, and the upper-storey ceiling (or the roof, if the attic is heated).

Building codes now require building envelopes to have a continuous air barrier. In new house construction, you may see builders installing a "house wrap" on the exterior or carefully sealing polyethylene sheeting on the interior. In older houses, which were built before air barriers were well understood or required, various materials act as a partial air barrier. In a typical house, the air barrier can include the polyethylene, gypsum board or plaster, wood framing, windows, doors, foundation walls, basement slab, caulking and weatherstripping. Most air leakage occurs at the joints between materials and at openings, rather than through the materials themselves. For air leakage to occur through the building envelope, two things are necessary: a hole and a pressure difference.

There is no shortage of "holes" in your house—in fact, if you combined all the cracks and leaks in a typical older home, you would have a hole almost big enough to crawl through! Aging tends to make a house leakier, as framing members shrink and cracks open up. Also, renovations and maintenance work can inadvertently open holes in the air barrier.

What about pressure differences?

These arise from four factors:

1. Temperature difference between indoors and outdoors—causing what's known as "stack effect"—is the most significant overall factor. This creates a positive pressure in the upper part of a house, which forces indoor air outward (remember, warm air rises), and a negative pressure in the lower part of the house, which draws outdoor air inward. On a cold day in winter, these stack pressures can be large, while on a mild day in the spring or fall, there may be almost no stack effect at all.

2. Wind creates a positive pressure outside the house on the windward side, forcing air inward, and a negative pressure on the leeward side and over the roof, drawing air outward. Air leakage from wind is the dominant factor on a windy day.
3. Chimneys expel combustion gases from furnaces, boilers, fireplaces and wood stoves, creating a negative pressure indoors. That's why you feel a draft at your back when sitting facing the fireplace.
4. Ventilation equipment and appliances, such as exhaust fans, clothes dryers and central vacuums, also create a negative pressure in the house by exhausting air.

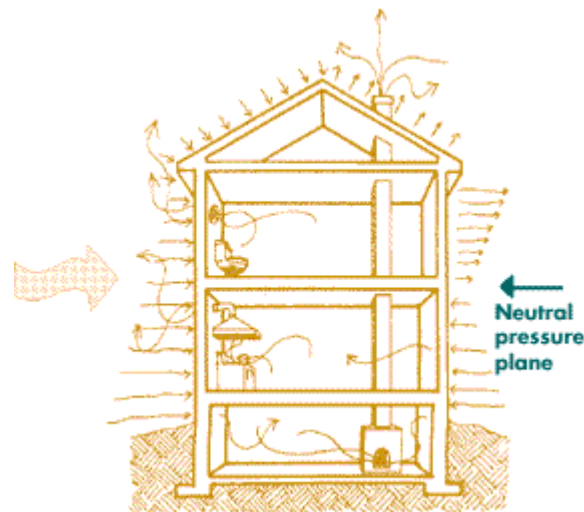

Forces causing air leakage

These four factors combine to create a constantly changing pattern of air leakage in a typical house. However, in general, air will be found leaking *in at the bottom* of a house and *out at the top*. Somewhere between the top and bottom of the house there will be an area where there is very little leakage in or out. Researchers call this the "neutral pressure plane"— a nice phrase to drop into a casual conversation with your neighbours!

Some leakage paths can be very direct, like wind whistling in under a door. Other leakage paths can be hidden and complex, with air travelling considerable distance through walls, ceiling spaces and plumbing chases. Sealing the outlet may not solve the problem if the outside hole remains unsealed. For example, cold air leaking out of an electrical outlet on an interior wall may be caused by outdoor air following a long path from an exterior opening through interior partitions.

Don't become a statistic!

More than a dozen people die every year in Canada because of carbon monoxide poisoning. What does this have to do with air sealing? Fuel-burning equipment—furnaces, hot water heaters, boilers, fireplaces and wood stoves—require air for

combustion and for exhausting their combustion products. Advanced equipment, such as a high-efficiency furnaces, has its own air supply and exhaust fans. However, conventional equipment may rely on house air for combustion and on "natural draft" to move the combustion products up the chimney flue. Such equipment —if starved for air or overpowered by a powerful exhaust fan elsewhere in the house—can spill carbon monoxide and other dangerous gases indoors. So, before air sealing your house, check with your local fuel supplier or municipal fire inspector to ensure that your fuel-burning equipment has a proper supply of combustion air. Chimneys should also be regularly cleaned and inspected for blockage. Powerful kitchen and bathroom exhaust fans may require additional outside air to prevent backdrafting. Conventional fireplaces are a problem, particularly if they are located in a basement with a chimney on an exterior wall—opening a window may be required for safe operation. **It is wise to install a carbon monoxide detector if you have fuel-burning equipment.**

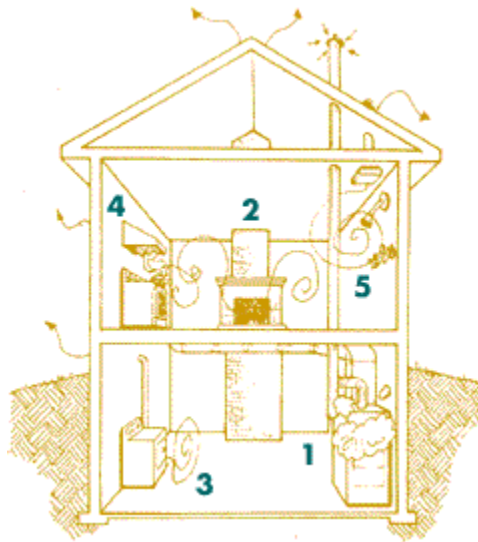

Combustion spillage caused by exhaust devices overpowering the furnace

- 1) natural draft furnace spills combustion products into house
- 2) fireplace draws excessive air, causing other equipment to backdraft, and can spill at the end of a burn
- 3) dryer,
- 4) range hood and
- 5) exhaust fans depressurize interior of house

Where Can I Get More Information?

This fact sheet is intended to provide you with a general introduction to air-leakage control. The following publications contain more detailed information.

Consumer's Guide to Buying Energy-Efficient Windows and Doors

Keeping the Heat In

Moisture Problems

Operating and Maintaining your Heat Recovery Ventilator (HRV)

Energy Publications
Office of Energy Efficiency
c/o DLS
Ottawa, ON K1A 0S9
Telephone: 1-800-387-2000
Fax: (819) 994-1498
Web site: <http://oee.nrcan.gc.ca/infosource>

The Clean Air Guide: How to Identify and Correct Indoor Air Problems in Your Home

Canada Mortgage and Housing Corporation (CMHC)
Canadian Housing Information Centre
700 Montreal Road
Ottawa, ON K1A 0P7
Telephone: 1 800 668-2642
Fax: (613) 748-4069
Web site: <http://www.cmhc-schl.gc.ca>

More information can be obtained from the Office of Energy Efficiency at Natural Resources Canada, and from your provincial energy and environment ministries and electric and gas utilities

Air Sealing Contractors

Unfortunately, most Yellow Pages™ do not have a listing for "air sealing", since it's a very specialized field. When getting estimates from contractors for air leakage control work, ask about their past experience. Have they been involved in an air-sealing program offered by a utility or a government agency? Have they taken any training courses in air-leakage control?

[View other](#) | [View to Print](#) | [Previous Section](#)

